

Durastroke 1500 Pneumatic Kit

- Features Durastroke 1100 Pneumatic Actuator
- Complete with Fisher 67 CFR Filter Regulators and Fisher 646 I/P Transducer
- Pre-Assembled
- Pre-Plumbed
- Factory Calibrated
- Durable Cast Aluminum Housing For Actuator
- Long Life Actuator Diaphragm



- Automatic Louver Control
- Field Installation requires only connecting two air lines
- Stainless Steel Travel Stem
- Complete with Aluminum Clevis
- Available for Extreme Duties

Airtech Products, Inc.
1550 S. 81st W. Avenue
Tulsa, OK 74127
Phone: 918-241-0264
Fax: 918-241-0270
www.airtechproducts.com

Technical Information

Actuator Construction

Aluminum Housing	356 -T6
Travel Stem	303 Stainless Steel
Clevis	6061-T6
Diaphragm (Standard)	Nitrile (Buna N) ASTM D1418
Operating Temperature (Std)	-40° F to 180° F
Operating Temperature (Extreme)	-60° F to 180° F (See Note)
(Note: Fisher 646 I/P Warranted only to -40° F)	

Operational

Consumption (Full Stroke)	.5	scfm
Consumption (at Positioner)	.24	scfm
I/P Transducer Consumption	.13	scfm

Stem Forces

- Net Extending Force (30 psig air) 620 Pounds
- Net Retracting Force (spring preloaded) 320 Pounds

Stem Travel 3.5 inches

Weight 65 Pounds

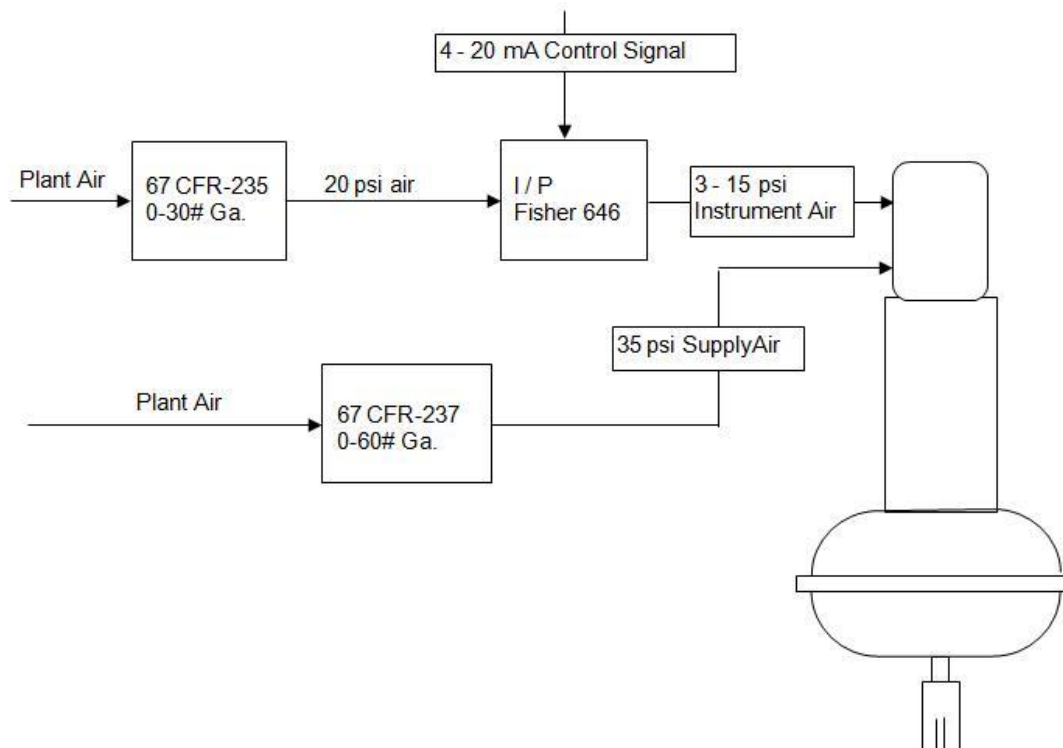

Airtech Products, Inc., 1550 S. 81st W. Avenue, Tulsa, OK 74127
Phone: 918-241-0264, Fax: 918-241-0270

www.airtechproducts.com