

Drive Sentry – Gen2

Anti Windmilling Device



The right answer for elimination of damaging fan “reverse direction” wind-milling has been improved with the Gen2 Drive Sentry.

The Drive Sentry, Gen2:

- Allows One-Way Rotation
- Fast and easy installation
- Easy field reversible for Right or Left-Hand Rotation
- Low Profile
- Attaches directly to fan shaft
- Maintenance free
- 6061-T6 Aluminum housing
- Stainless Steel hardware
- Quality machined finish
- Field tested, proven design
- Fast delivery
- Low cost
- Includes all parts required for installation
- Weighs only 3.5 pounds
- For forced or induced draft designs



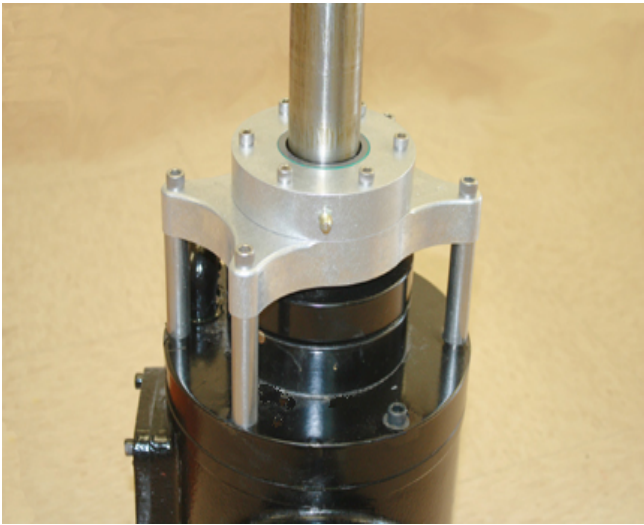

Technically Superior

- Developed and modeled using state of the art computer software.
- Lab tested and verified on Chatillion Series 500 force tester.
- Withstood 286.7 Ft-Lbs torque before overcoming clutch.
- Run out less than .00001".
- Rolling friction test per ASTM G194-08 was "negligible".

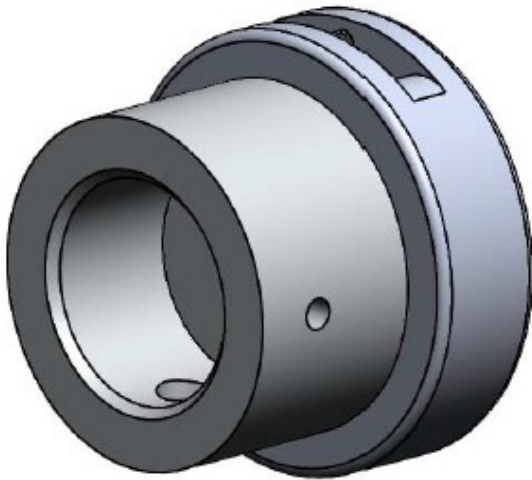

User Friendly

- Available for all common fan shaft diameters
- RH or LH rotation field-changeable
- Installs in minutes
- No special tools required for installation. Installs using two hex wrenches
- All parts required for installation are included with shipment
- No maintenance required
- Requires only 1.5" of fan shaft projection
- Low profile - will fit under most guards without need for modification
- Bushing mounted units

