



CONVERTING DURASTROKE 1100 PNEUMATIC ACTUTOR TO DURASTROKE 1000.

(Instruction for removing positioner and installing cover plate)

Installation

1. Observe all safety precautions – make the proper lock outs to ensure the safety of manpower and protection of equipment.
2. Remove the six screws holding the positioner and gasket in place. At your option, these parts can be retained or discarded. – none will be reused for this modification.
3. Remove the positioner (#25), gasket (#24), positioner spring (#22) and positioner washer (#23) from actuator body.
4. Lay the cover gasket (#24) in place and set the cover on top of the actuator housing. Install the six cap screws and tighten in a star pattern until all are firm / snug.

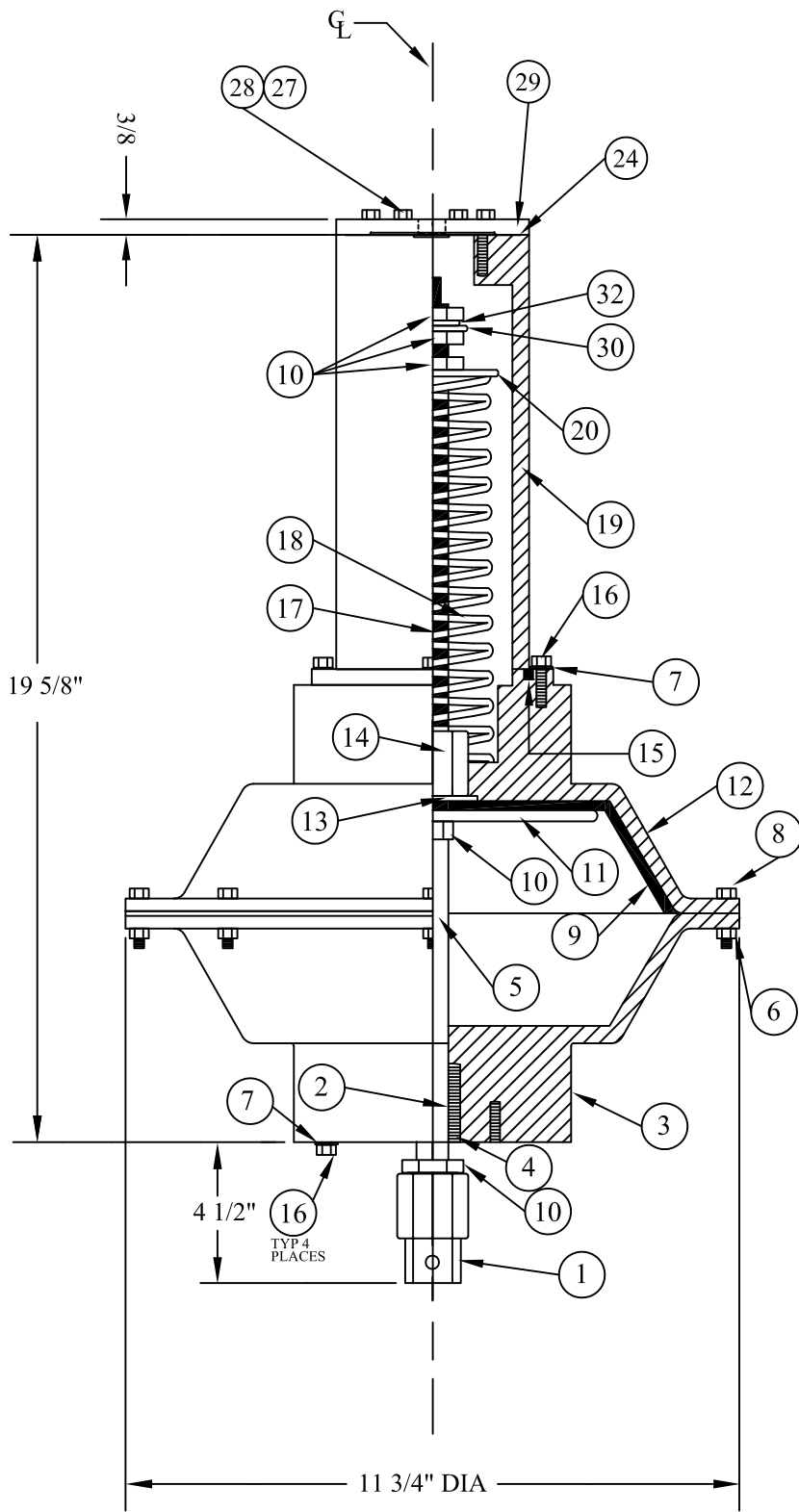

ITEM	QTY.	DESCRIPTION
1	1	CLEVIS
2	1	GUIDE BUSHING
3	1	LOWER HOUSING
4	1	SNAP RING
5	1	STEM
6	8	NYLOCK HOUSING NUT
7	8	LOCKWASHER
8	8	3/8"-16 X 1.5" HOUSING SCREW
9	1	DIAPHRAGM
10	5	3/4"-16 JAMNUT
11	1	DIAPHRAGM PLATE
12	1	UPPER HOUSING
13	1	DIAPHRAGM WASHER
14	1	CONNECTOR NUT
15	1	O-RING
16	8	3/8"-16 X 1 1/4" SPRING COVER SCREW
17	1	SPRING ROD
18	1	MAIN SPRING
19	1	SPRING COVER
20	1	SPRING WASHER
21		
22		
23		
24	1	GASKET
25		
26		
27	6	LOCKWASHER
28	6	COVER PLATE SCREW
29	1	COVER PLATE
30	1	3/4" FLAT WASHER
31		
32	1	3/4" SAE FLAT WASHER

AIRTECH PRODUCTS, INC.

Dwg. Name:
DURASTROKE 1000-1049 ACTUATOR

Date:
11-10-15

By:
Stewart

Customer:

File #:

AIR MOTOR

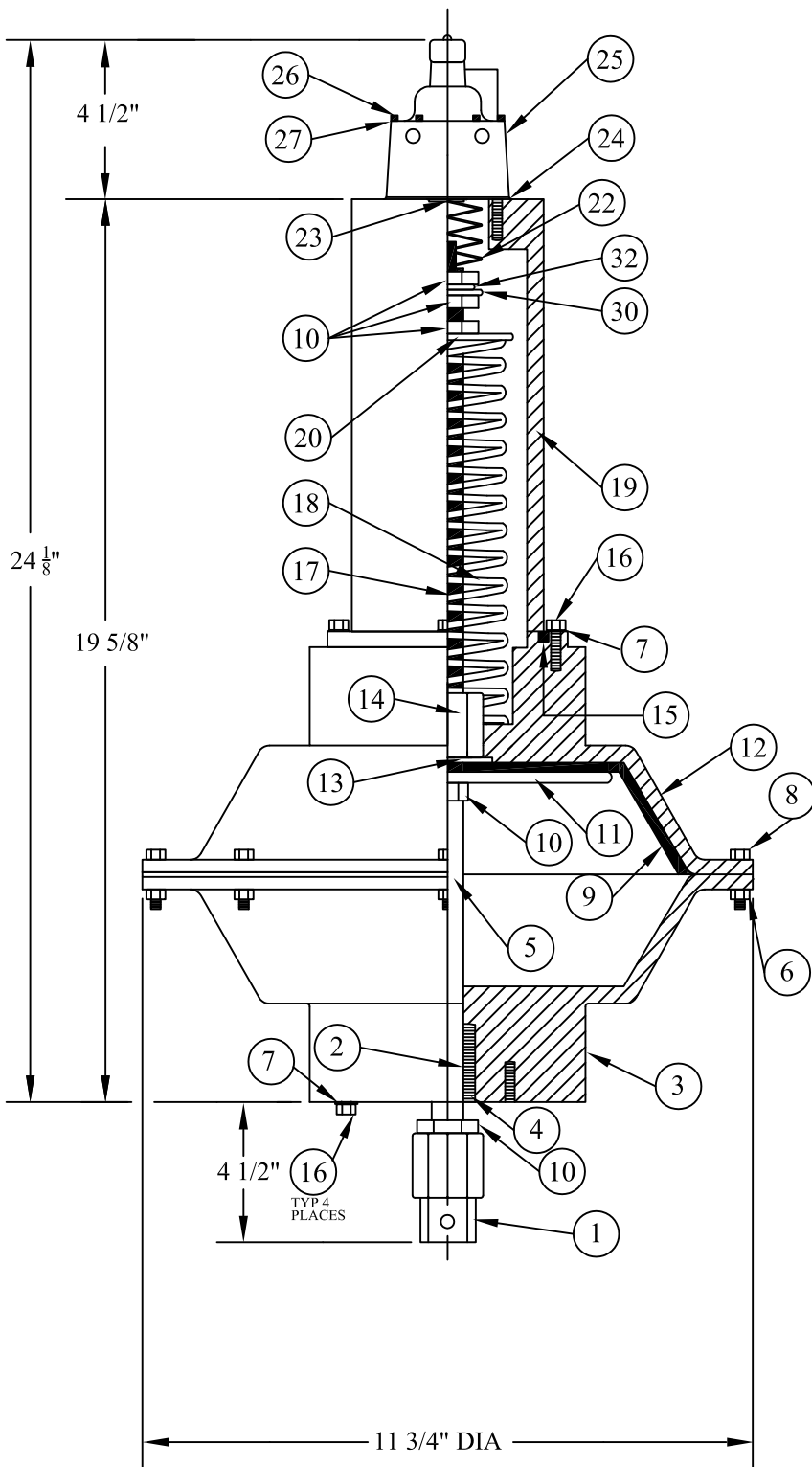

ITEM	QTY.	DESCRIPTION
1	1	CLEVIS
2	1	GUIDE BUSHING
3	1	LOWER HOUSING
4	1	SNAP RING
5	1	STEM
6	8	NYLOCK HOUSING NUT
7	8	LOCKWASHER
8	8	3/8"-16 X 1.5"
		HOUSING SCREW
9	1	DIAPHRAGM
10	5	3/4"-16 JAMNUT
11	1	DIAPHRAGM PLATE
12	1	UPPER HOUSING
13	1	DIAPHRAGM WASHER
14	1	CONNECTOR NUT
15	1	O-RING
16	8	3/8"-16 X 1 1/4"
		SPRING COVER SCREW
17	1	SPRING ROD
18	1	MAIN SPRING
19	1	SPRING COVER
20	1	SPRING WASHER
21		
22	1	POSITIONER SPRING
23	1	POSITIONER WASHER
24	1	GASKET
25	1	POSITIONER
26	6	1/4"-20 X 3"
		POSITIONER SCREW
27	6	1/4" S.S. LOCKWASHER
28		
29		
30	1	3/4" FLAT WASHER
31		
32	1	3/4" SAE FLAT WASHER

AIRTECH PRODUCTS, INC.

Dwg. Name:
DURASTROKE 1100-1149 ACTUATOR

Date:
11-11-15

By:
Stewart

Customer:

File #:

AIR MOTOR