



Pneumatic Actuator

Durastroke Series 2000

Installation & Maintenance Instructions

INSTALLATION

Installation of Airtech Products Durastroke pneumatic actuator is a simple three-step process; Mounting of the actuator & attachment to load, connection of air line and connection of the control signal. Before starting installation, inspect the actuator and contents of the shipping carton to ensure all required parts are present.

Check the following:

- Ensure the positioner is firmly secured to the actuator body.
- Clevis is present at the end of travel stem?
- The following hardware kit was included:
 1. Five (5) 3/8-16 x 1 1/2" long bolts
 2. Four (4) 3/8" lock washers
 3. One (1) 3/8-16 locking nut

A) Mounting The Actuator:

1. The actuator can be mounted in either a vertical or horizontal position.
2. The actuator is supplied with four (4) 3/8"-16 bolt-holes in the bottom plate for attachment to a mounting plate or bracket.
3. A hole at least 13/16" (but not larger than 1" diameter) must be provided in the center of the actuator mounting bolthole pattern for penetration of the actuator travel stem and clevis.
4. Attach the actuator to the mounting bracket with the four supplied 3/8"-16 x 1 1/2" bolts and lock washers. In a rotating pattern, tighten each to 16 Ft-Lbs torque.
5. **DO NOT ATTACH THE ACTUATOR TO THE TORQUE TUBE LEVER ARM YET.**

B) Air Line Connections:

1. Blow out all piping before connections are made to prevent dirt, chips, etc from entering the positioner. Ensure all air entering the positioner and actuator is clean, dry and oil free. Failure to do so increases the possibility of operational problems and/or deviation from specified performance.
2. Locate the 1/4" NPT ports on the Fisher DVC Positioner.
3. Install a 1/4" threaded adapter in the air inlet port. Use Teflon tape or a non-hardening sealant on the male threads of connectors.
4. Connect 1/4" or 3/8" air line to the supply port on the positioner. 125 psig is the suggested maximum total air pressure in this line.

C) Control Signal Connection:

1. Locate the 1/2" NPT port for the conduit connection and install male adapter.
2. Connect conduit and thread wiring into transducer connection terminals
3. Connect leads for control signal to corresponding terminals in Positioner.
4. Securely reinstall cap.

D) Connecting The Linkage:

1. In most cases**, the torque tube lever arm will be preset at the factory to drive the louver either “Fail Open” or “Fail Closed” upon loss of air and / or actuator retraction. As a result, connection of the linkage will be a simple matter of manually situating the louver blades and actuator stem to the correct position and then attaching the control link to the clevis (at the base of the actuator stem) and finally to the torque tube lever arm. To determine how the actuator and louver blades should be positioned, please note the following instructions:
 - a. **“Fail Open” Louvers**
 - Stroke actuator to fully extended and manually set louver to fully closed position before connecting louver lever arm & link to actuator clevis.
 - b. **“Fail Closed” Louvers**
 - Ensure actuator is completely retracted and manually set louvers to fully closed position before connecting louver lever arm & link to actuator clevis.
2. When all sections are installed and connected, stroke the actuator several times to ensure it moves the entire louver freely without binding or interference. On very large louvers with multiple sections, inspect to confirm all the sections are fully open and completely closing in unison. Some adjustment of end links or torque tube clamps may be required to ensure all louver blades open and shut consistently down the entire length or across the entire width of the louver.
3. Check all attachment fasteners to ensure all are properly tightened and completely engaged to the louver flange.
4. If applicable, check all end link connections and torque tube couplers to ensure they are properly tightened and fasteners are completely engaged.

****For new orders only when the actuator is purchased in conjunction w/louvers.** Please contact the factory for specific instructions on retrofit or other applications that did not see both the actuator and louver originate as simultaneous/concurrent Airtech orders

MAINTENANCE

Annual Inspection:

1. Inspect and verify all mechanical connections
 - Positioner & mounting bracket bolting to actuator body
 - Check mounting bracket rigidity
 - Confirm actuator to mounting bracket bolt tightness
 - Clevis general condition
 - Visually inspect overall clevis condition
 - Confirm fastener between clevis and actuator link is sound
 - Link to torque tube lever arm
 - Visually inspect overall link condition
 - Confirm fastener between link and torque tube lever arm is sound
 - Positioner attachment to actuator body
 - Visually inspect positioner for visible cracks or damage
 - Confirm positioner is securely fastened to actuator body

2. Inspect and verify all pneumatic and electrical connections
 - Air connections to positioner
 - Supply line to threaded adapters
 - Adapters to positioner
 - Diaphragm
 - Confirm pressure is present at Diaphragm
 - § Listen for leaks at stem

Repair Kit & Recommended Spare Parts List

The following items are recommended as a single actuator repair kit. It is suggested that one repair kit be kept on hand for each 3 actuators on site and in service. Please note a repair & maintenance kit is not offered for the positioner because of the complexity of that particular item. Best practice is simply to replace a non-operational positioner. Item numbers noted below refer to Airtech Products, Inc. drawing, "Durastroke 2000 Actuator".

<u>Item Number</u>	<u>Description</u>
2	Guide Bushing
4	Snap Ring
9	Diaphragm
13	Diaphragm Washer
15	O-Ring
25	Kit, Positioner, Fisher DVC 6010

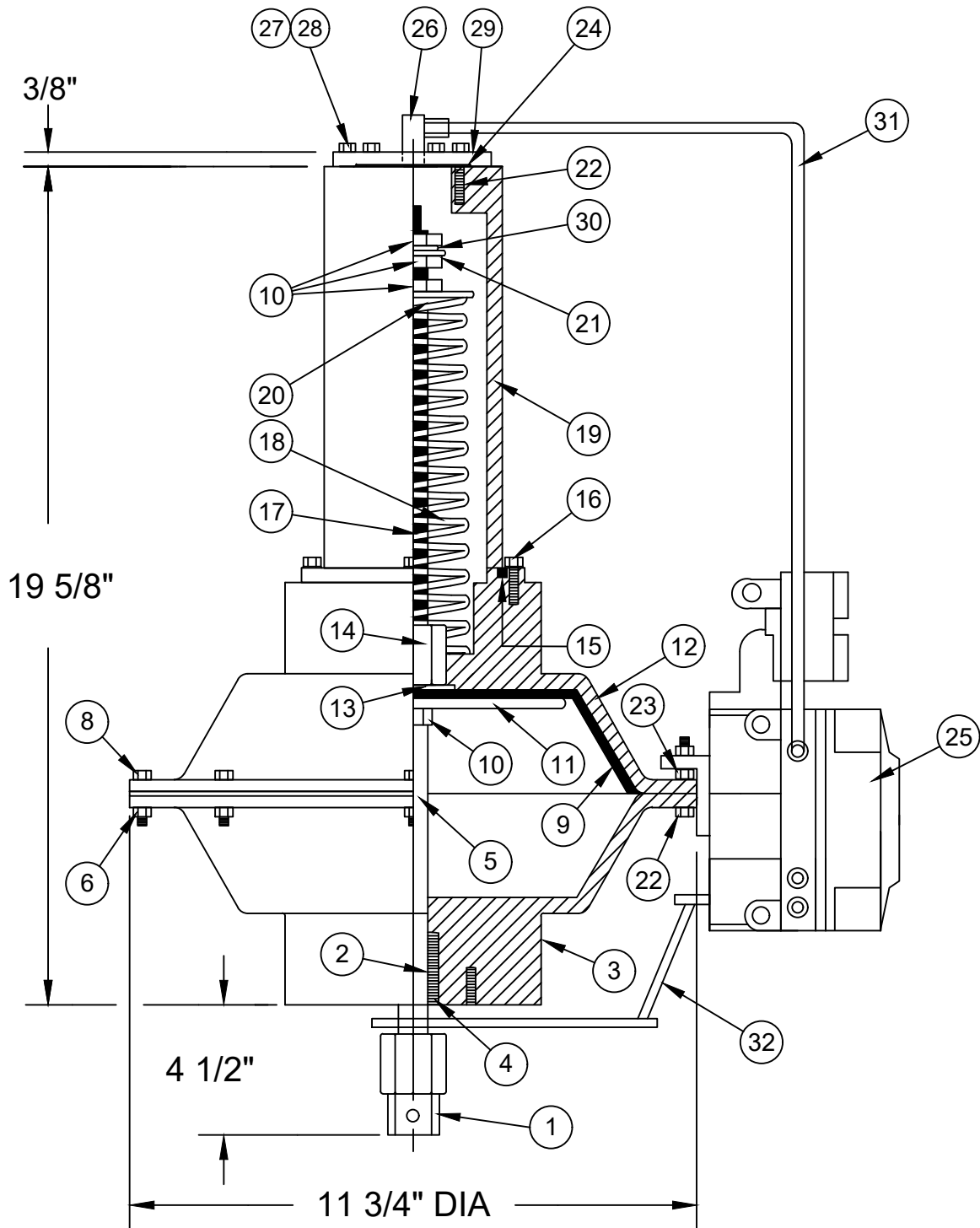

ITEM	QTY.	DESCRIPTION
1	1	CLEVIS
2	1	GUIDE BUSHING **SEE NOTE
3	1	LOWER HOUSING
4	1	SNAP RING
5	1	STEM
6	8	HOUSING NUT, ESNA
7	11	LOCKWASHER
8	12	3/8"-16 X 1-1/2" HOUSING SCREW
9	1	DIAPHRAGM
10	3	3/4"-16 JAMB NUT
11	1	DIAPHRAGM PLATE
12	1	UPPER HOUSING
13	1	DIAPHRAGM WASHER
14	1	CONNECTOR NUT
15	1	O-RING
16	4	3/8-16 X 1-1/4" SPRING COVER SCREW
17	1	SPRING ROD
18	1	MAIN SPRING
19	1	SPRING COVER
20	1	SPRING WASHER
21	1	3/4" FLAT WASHER
22	1	HOUSING SCREW, 3/8 X 1 3/4
23	1	HOUSING NUT, 3/8 STD.
24	1	GASKET
25	1	POSITIONER, DVC 6200
26	1	1/4" NPT FITTING
27	6	LOCKWASHER
28	6	COVER PLATE SCREW
29	1	COVER PLATE
30	1	SAE FLAT WASHER
31	1	3/8" TUBING
32	1	POSITIONER LINKAGE

** GUIDE BUSHING WAS ELIMINATED ON ALL UNITS PRODUCED AFTER 15 JULY 2017

 <small>PRODUCTS, INC. 1550 S., 81ST W. AVE., TULSA, OK. 74127</small>	
Dwg. Name: DURASTROKE 2000 ACTUATOR	
Date: 2/5/2020	By: PR
Customer: STANDARDS	File #: D2000 PARTS