



## Durastroke Model 60/65 & 120/125 Series Pneumatic Actuator Installation & Maintenance Instructions

### **INSTALLATION**

Installation of Durastroke 60 & 120 Series pneumatic actuator is a simple three-step process consisting of mounting the actuator, attachment to load and connection of air line(s). Before starting installation, inspect the actuator and contents of the shipping carton to ensure all required parts are present. Check the following:

- Clevis is present at the end of travel stem?
- The following hardware is present on the pivot mount:
  1. Two (2) 3/8" flat washers.
  2. One (1) 3/8-16 nylon insert locking nut

### **A) Mounting The Actuator:**

1. The actuator can be mounted in either a vertical or almost horizontal position. The actuator should not be installed horizontal or at a downward slope to prevent water from running inside the housing into the mechanism and diaphragm.
2. A 1/2" diameter hole in the mounting bracket, cooler wall panel or host structure is required for attachment of the pivot mount.
3. Loose fit the lever arm to the torque tube (the pipe that rotates to drive the louvers open and closed) and the clevis at the base of the actuator stem. Using the bolt projecting from the pivot mount, mark the location of the hole to be drilled. Drill a 1/2" diameter hole. Remove the nylon insert nut and one flat washer from the mounting bolt and insert the bolt through the just drilled hole. Install one flat washer and then firmly tighten the nylon insert nut on the mounting bolt.
4. Leave the lever arm clamp loose at the torque tube for the moment. You may need to rotate the torque tube by hand before final tightening is done.

### **B) Air Line Connection(s):**

The actuator is shipped with a thread protector pushed into the 1/4" NPT inlet port located at the center of the top cap.

1. Remove the cover and install a 1/4" threaded adapter to the inlet port then connect 1/4" or 3/8" air line to adapter. The air pressure in this line should be regulated between 30-40 psig.

### **C) Connecting The Linkage:**

1. In most cases\*\*, the torque tube lever arm will be preset at the factory to drive the louver either "Fail Open" or "Fail Closed" upon loss of air and / or actuator retraction. As a result, connection of the linkage will be a simple matter of manually situating the louver blades and actuator stem to the correct position and then attaching the lever arm to the clevis (at the base of the actuator stem). To determine how the actuator and louver blades should be positioned, please note the following instructions:

#### **a. "Fail Open" Louvers**

- Stroke actuator to fully extended and manually set louver to fully closed position before connecting louver lever arm & link to actuator clevis.

#### **b. "Fail Closed" Louvers**

- Ensure actuator is completely retracted and manually set louvers to fully closed position before connecting louver lever arm & link to actuator clevis.

2. With everything installed, connected and tightened, stroke the actuator several times to ensure it moves the entire louver freely without binding or interference. On very large louvers with multiple sections, inspect to confirm all the sections are opening and closing in unison. Some adjustment of end links or torque tube clamps may be required to ensure all louver blades open and shut consistently down the entire length or across the entire width of the louver.
3. Check all attachment fasteners to ensure all are properly tightened and completely engaged to the louver flange.
4. If applicable, check all end link connections and torque tube couplers to ensure they are properly tightened and fasteners are completely engaged.

**\*\*For new orders only when the actuator is purchased in conjunction w/louvers.** Please contact the factory for specific instructions on retrofit or other applications that did not see both the actuator and louver originate as simultaneous/concurrent Airtech orders

## **MAINTENANCE**

### **Annual Inspection:**

1. Inspect and verify all mechanical connections
  - Actuator bolting to mounting plate or bracket
    - Check mounting plate or bracket rigidity
    - Confirm actuator to mounting bracket bolt tightness
  - Clevis general condition
    - Visually inspect overall clevis condition
    - Confirm fastener between clevis and actuator link is sound
  - Link to torque tube lever arm
    - Visually inspect overall link condition
    - Confirm fastener between link and torque tube lever arm is sound
  - Positioner attachment to actuator body (if applicable)
    - Visually inspect positioner for visible cracks or damage
    - Confirm positioner is securely fastened to actuator body
2. Inspect and verify all pneumatic connections
  - Instrument air (if applicable)
    - Supply line to threaded adapter
    - Adapter to positioner
  - Supply air
    - Supply line to threaded adapter
    - Adapter to positioner
  - Diaphragm
    - Confirm 35-50 psig air at Supply Port
      - § Listen for leaks at stem
  - Positioner (if applicable)
    - Confirm 3 – 15 psig at instrument air port
      - § Confirm louver operation in response to proportioned air

## **Repair Kit & Recommended Spare Parts List**

The following items are recommended as a single actuator repair kit. It is suggested that one repair kit be kept on hand for each 3 actuators on site and in service.

<b><u>Item Number</u></b>	<b><u>Description</u></b>
1	Clevis
2	Jamb Nut
5	Diaphragm
6	Housing Screws w/Flat Washer (4)
9	Spring, 3-15 or 6-30

12-22-08

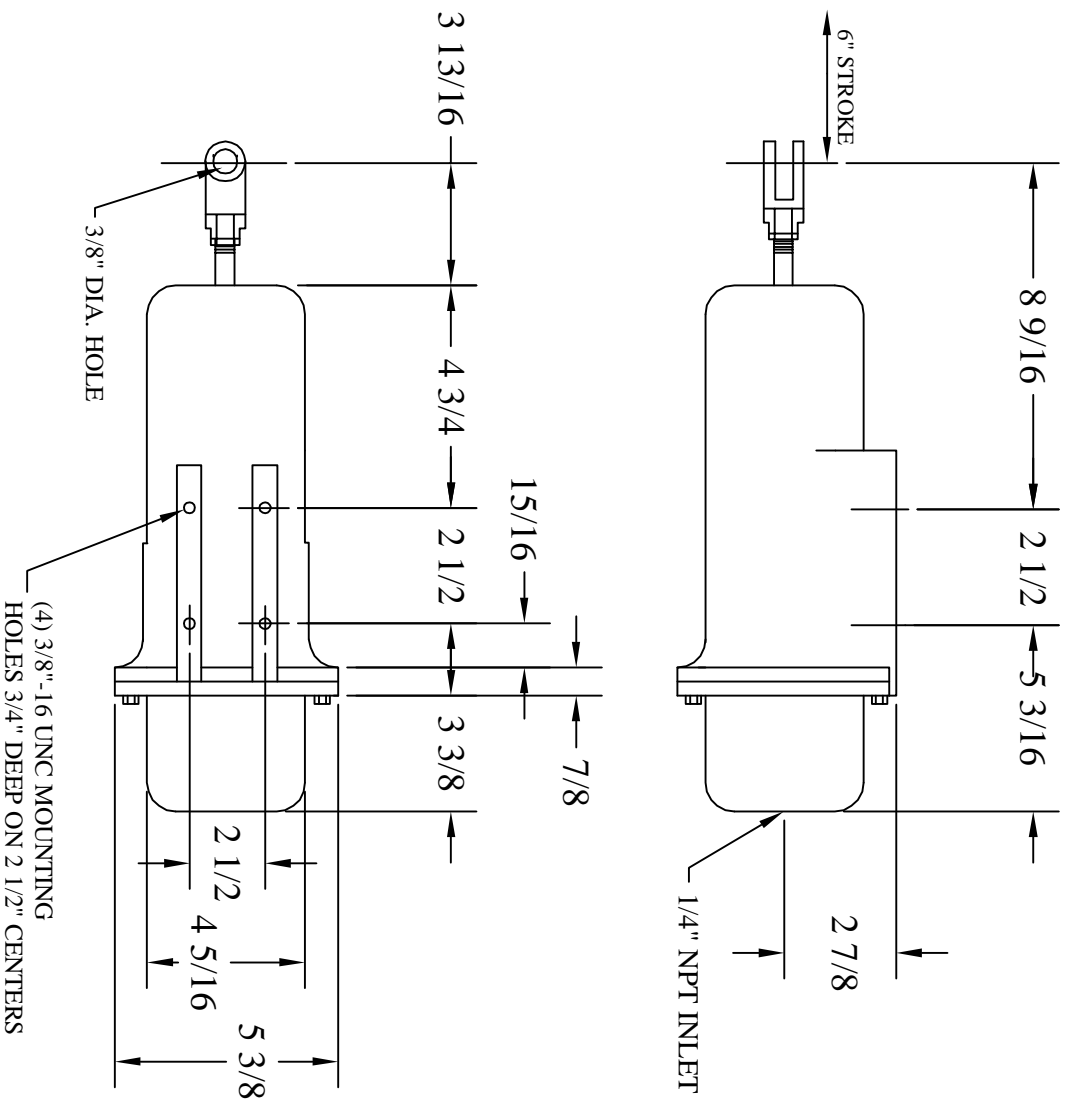

## Design and Construction

Housing:	356-T6 Alum.
Travel Stem:	303 Stainless Steel
Piston:	356-T6 Alum.
Includes Clevis:	Yes
Clevis Material:	Zinc Plate
Available force:	
3 - 15 Spring (3 psi)	18#
6 - 30 Spring (6 psi)	36#
Stem Travel:	4"
Consumption (Full Stroke)	.01 scf
At positioner	.3 scf (40 psi)
Weight:	
With Positioner	14.75 Lbs.
Without Positioner	12.75 Lbs.
Spring:	Zinc Plated
Extreme duty available:	Optional
Use w/Air or Sour Gas:	Yes
Lubrication Required:	No

**AIRTECH PRODUCTS, INC.**

Dwg. Name:  
**DURASTOKE 120 ACTUATOR**

Date: 9-21-06	By: Miller
Customer:	File #:

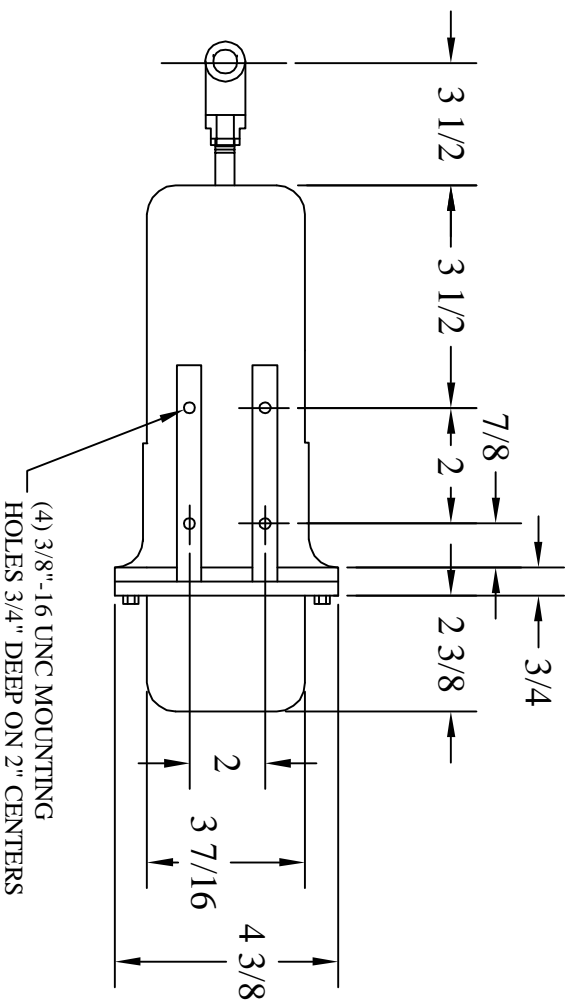
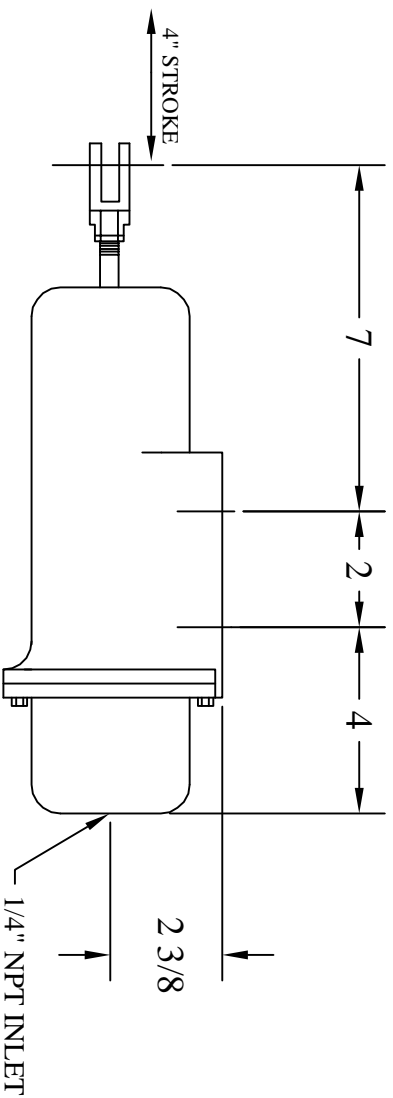

## Design and Construction

Housing:	356-T6 Alum.
Travel Stem:	303 Stainless Steel
Piston:	356-T6 Alum.
Includes Clevis:	Yes
Clevis Material:	Zinc Plate
Available force:	
3 - 15 Spring (3 psi)	18#
6 - 30 Spring (6 psi)	36#
Stem Travel:	4"
Consumption (Full Stroke)	.01 scf
At positioner	.3 scf (40 psi)
Weight:	
With Positioner	8.25 Lbs.
Without Positioner	6.25 Lbs.
Spring:	Zinc Plated
Extreme duty available:	Optional
Use w/Air or Sour Gas:	Yes
Lubrication Required:	No

**AIRTECH PRODUCTS, INC.**

Dwg. Name:  
**DURASTOKE 60 ACTUATOR**

Date: 9-21-06	By: Miller
Customer:	File #: